

Advanced Electrical Materials For Traction Current Collectors

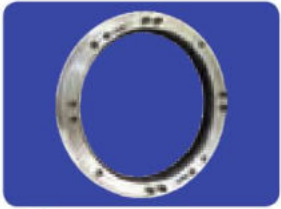

Traction Package



1 Aegis SGR™



2 Wheel Flange Lubrication



3 Earthing Unit

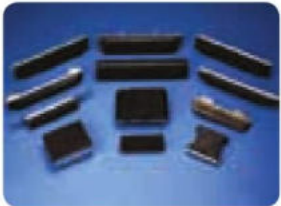

4 3rd Rail Shoes

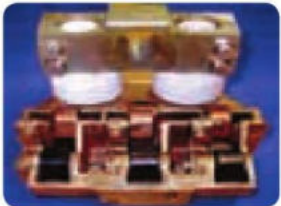

5 Holders



6 Brushes and Contacts



7 Pantograph Carbons

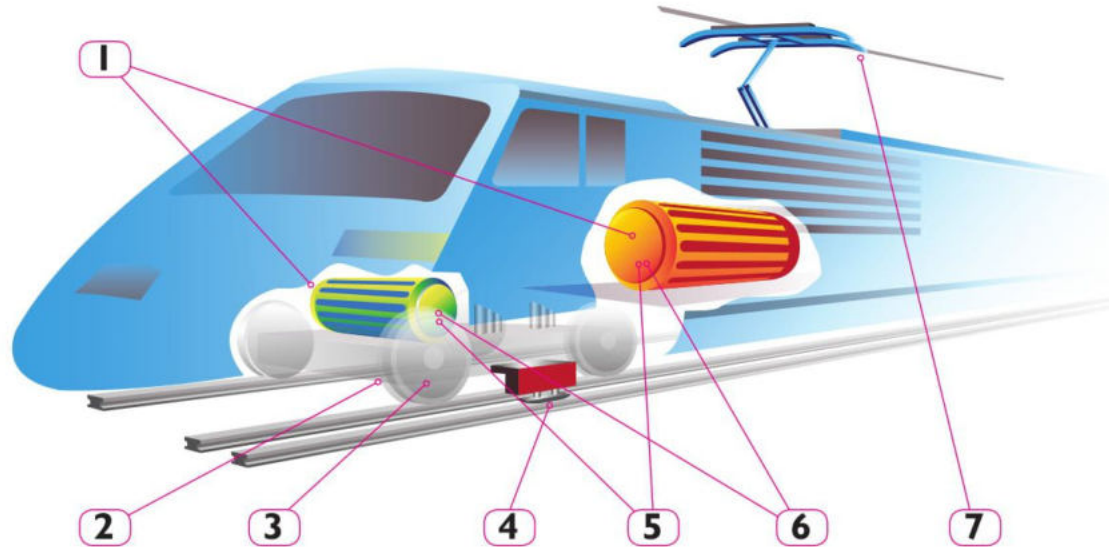

Carbon exhibits many operational and financial advantages over metallic materials as a linear current collector, and the benefits to user systems are becoming increasingly apparent as more of the world's railway, third rail and tram/trolleybus systems change to carbon.

Overhead current collection

On pantograph systems, the advantages of carbon include:

- Longer collector strip life, with lower maintenance costs and less frequent replacement
- Longer wire life, giving significant reductions in cost of maintenance for the overhead system
- Reduced mass for better current collection
- Carbon's inert qualities, which ensure that carbon will not weld to the conductor wire - even after long periods of static current loading
- The ability to operate at high speeds (300km/hour and more)
- The virtual elimination of electrical interference to telecommunications and signal circuits
- Negligible audible noise between rubbing surfaces.
- Laboratory and field comparisons between carbon and copper, sintered bronze or aluminium pantograph collector strips show many examples of up to tenfold increase in collector and wire life and recent studies in Japan show a projected 25% saving in total system operating costs.

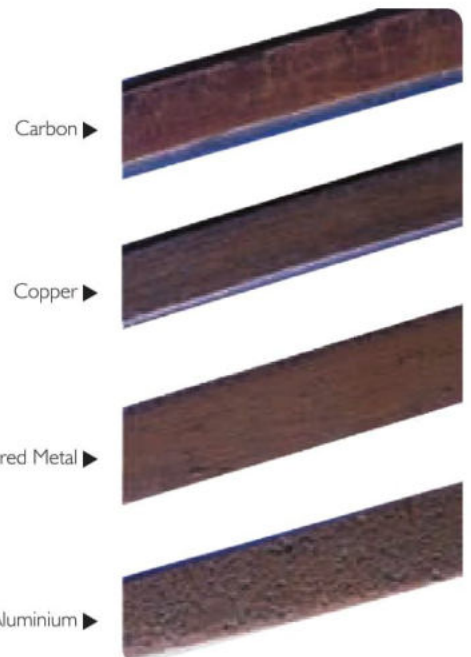
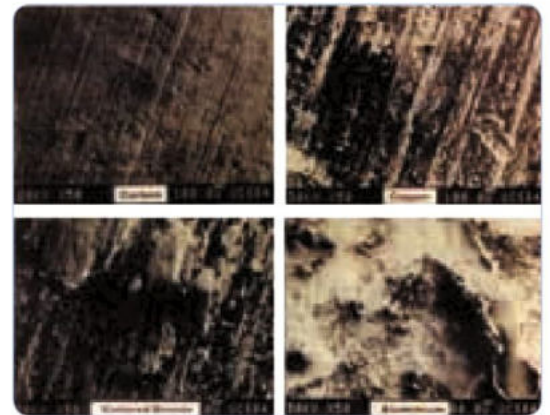

Pantograph Strips

Morgan Offer a variety of collector strips to suit all your designs. Whatever your requirement Morgan Advanced Materials have the Pantograph strip for all applications.

Morgan Advanced Materials supply:-

- Full length metalised carbons
- Fitted and Integral end horns
- Kasperowski high current including auto drop in this design
- Light weight bonded Aluminium designs
- Auto-Drop collector strips
- Arc protected collectors
- Heated collectors
- Ice breaker collectors
- High current bonded collectors

Whether it's crimped, rolled, tinned, soldered, or bonded Morgan Advanced Materials offers the best solution for retaining the carbon in the sheath.



Integral end horn



Lightweight bonded aluminium



Kasperowski



Soldered



Fitted end horn

Self Supporting Collector Strips

Morgan Advanced Materials supply mainline railway systems with self supporting carbon collector strips including epoxy bonding of carbon to aluminium providing

- Reduction in pan head mass
- Improved dynamic response
- Reduction in maintenance and service costs

Morgan Advanced Materials has a unique method of achieving high mechanical strength whilst maintaining low resistance between carbon and metal carrier. Morgan Advanced Materials have also developed a unique method of transferring high currents to give a low resistance current path in bonded collectors, resulting in an innovative light weight solution for DC applications.

Please contact us for a complete 3rd party reference list. Credited with DIN 6701-2

Morgan Advanced Materials offer a variety of designs to suit your applications including arc protection alternatives.



Morgan is an approved supplier to many systems worldwide including:

- | | |
|--------------------------|------------------|
| • Deutsche Bahn AG | • Austrian Rail |
| • MAV Hungary | • SNCF |
| • PKP | • Amtrak USA |
| • New Jersey Transit USA | • Shanghai China |
| • Guangzhou China | • MTRC |
| • NEDTRAIN Trenitalia | • UK Rail |

Auto Drop Impact Detection System

Many high speed systems incorporate an impact detection system within the collector strip. This device enables the pantograph to be lowered if an impact was to occur severe enough to damage the pantograph head. The sensitivity of these systems varies according to the design, however the principle of all Auto-drop detection systems is the same.

The pantograph head is kept in place against the overhead wire by pneumatic pressure. When the carbon strip wears down to a particular level or is severely damaged, the air pressure is lost and the panhead drops away from the wire, preventing further damage. Morgan Advanced Materials have various designs which are running on many systems worldwide including UK railway systems, Deutsche Bahn AG, Le Shuttle, Eurostar, Austrian Rail, Amtrak USA, Delhi Metro India, and MTRC.

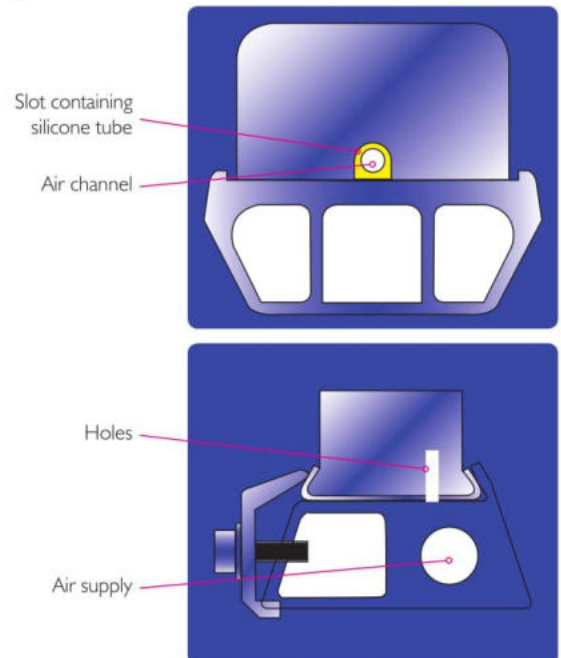

Materials for all Overhead Current Collection Systems

Morgan Advanced Materials is a leading global supplier to the Railway and Tramway Industry, providing products, services and solutions for current collector systems.

Morgan Advanced Materials offer technical support from our highly qualified engineers, who have experience and an in-depth understanding of collector systems.

Whether tramways, mail line or high speed applications our team have the material and design expertise to recommend the best solutions for your applications.



Material Grades for Overhead Current Collection

Grade	Description	Typical Running Current	Typical Static Current	Specific Resistance	Density	Transverse Bend Strength	Hardness
		(A/mm)	(A/mm)	($\mu\Omega\text{m}$)	(g/cm^3)	(MN/m^2)	Sceleroscope
CY3TA	Plain Carbon Lead Free	6	1	38	1.7	30	85
CY280	Plain Carbon Graphite Lead Free	6	1	38	1.6	35	75
MY7A	Metallised CY3TA for higher strength and lower resistance Lead Free	10	2	10	2.4	75	90
MY7A2	Metallised CY280 for higher strength and lower resistance Lead Free	14	2.3	5	2.5	70	75
MY7D	Metallised CY3TA for higher strength and lower resistance	14	2.3	5	2.7	90	92
MY258	As MY7D but with improved resistivity	16	2.3	3	2.9	90	92
MY258A2	Modified version of MY7A2 with added impregnation strength & resistivity Lead Free	18	2.7	<2	2.7	75	85
MY258P	Metallised pressed grade with very low resistivity Lead Free	20	5	<1	3.2	85	80
MY259	Metallised CY280 for higher strength and lower resistance	16	2.5	3	2.8	90	90
MY131	Metallised dense base carbon to give low weight version of metallised grade Lead Free	10	2	8	2.2	80	105

The standard values for static current are based on the following criteria: 4kg contact force per strip (8.8 lbs) 107mm² single wire catenary, partly worn 150oC max. catenary temperature (302oF)

Higher operating values are achievable under certain conditions. Please contact our engineers for further information, as typical running and static currents are for guidance only.

Carbon Inserts for Trolley Bus Shoes

Morgan Advanced Materials have longstanding experience in the transport market providing a breadth of application knowledge built up over time ensuring the best materials and designs.

Leveraging on this experience we supply trolley bus inserts that are durable and the best fit for this application, such as double tapered for a safe fit.



Material Grades for Trolley Bus Systems

Grade	Description	Typical Running Current	Specific Resistance	Density	Transverse Bend Strength	Hardness
		(A/mm contact length)	($\mu\Omega\text{m}$)	(g/cm^3)	(MN/m^2)	Sceleroscope
CY3TA	Plain Carbon Lead Free	2.5	38	1.7	30	85
CY280	Plain Carbon Graphite Lead Free	2.5	38	1.6	35	75
CY3WA	Impregnated carbon for improved wear Lead Free	2.5	38	1.9	30	90
MY7A	Metalised CY3TA for higher strength and lower resistance Lead Free	4	10	2.4	75	90
MY7A2	Metalised CY280 for higher strength and lower resistance Lead Free	4	5	2.5	70	75
MY7D	Metalised CY3TA for higher strength and lower resistance	4	5	2.7	90	92
MY258A2	Modified version of MY7A2 with added impregnation strength & resistivity Lead Free	4	<2	2.7	75	85
MY258P	Metalised pressed grade with very low resistivity Lead Free	4	<1	3.2	85	80
MY259	Metalised CY280 for higher strength and lower resistance	4	3	2.8	90	90
MY131	Metalised dense base carbon to give low weight version of metalised grade Lead Free	4	8	2.2	80	105

Higher operating values are achievable under certain conditions. Please contact our engineers for further information, as typical running and static currents are for guidance only.

Materials for Third and Forth Rail Applications

Third and Fourth Rail Systems

Steel, cast-iron, copper or bronze shoes on third and fourth rail collection systems inflict mechanical damage to the rail because of their relatively high mass. Their high co-efficients of friction also create excessive wear both to the collector and the rail. Once wear takes place, electrically conductive - and some times magnetic - debris is created, so motor windings and other systems must be protected. Inevitably sparking between damaged rail and collector also occurs, causing further problems of interference to telecommunications and signalling systems.

The use of carbon-based collector materials virtually eliminates all these problems. Carbon's relatively low mass (one third that of copper) minimises mechanical hammer damage to the rail, and its self-lubricating properties ensure a patina of carbon is deposited on the rail reducing friction and wear and almost completely eliminating sparking. As an added bonus, the carbon patina provides a degree of natural de-icing capability.

Carbon is particularly valuable as a collector material on systems using aluminium rails with stainless steel caps, where the margin for damage is greatly reduced.



Material Grades for Third and Fourth Rail Systems

Grade	Description/Application	Typical Running Current	Typical Static Current	Specific Resistance	Density	Transverse Bend Strength	Hardness
		(A/cm ²)	(A/cm ²)	(μΩm)	(g/cm ³)	(MN/m ²)	Sceleroscope
CY3TA	Plain Carbon Lead Free	10	5	38	1.7	30	85
CY280	Plain Carbon Graphite Lead Free	10	5	38	1.6	35	75
MY7A	Metalsed CY3TA for higher strength and lower resistance Lead Free	12	7	10	2.4	75	90
MY7A2	Metalsed CY280 for higher strength and lower resistance Lead Free	12	7	5	2.5	70	75
MY258A2	Modified version of MY7A2 with added impregnation strength & resistivity Lead Free	12	7	<2	2.7	75	85
MY258P	Metalsed pressed grade with very low resistivity Lead Free	12	7	<1	3.2	85	80
MY131	Metalsed dense base carbon to give low weight version of metalsed grade Lead Free	12	7	8	2.2	80	105
MY256	Metalsed material with improved life suitable for underground applications Lead Free	12	7	6	2.5	70	90

Higher operating values are achievable under certain conditions. Please contact our engineers for further information, as typical running and static currents are for guidance only.

Collector Sections

Examples of some of the available carbon sections - however we can design and manufacture to all application requirements. Please contact us for further section patterns.

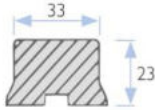
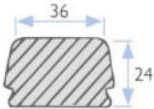
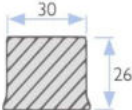
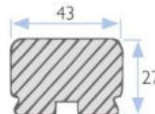
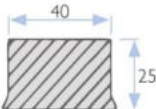
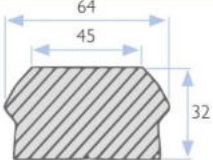
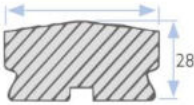
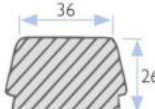
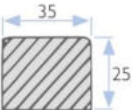
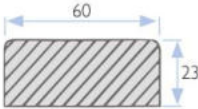
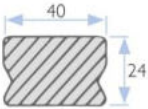
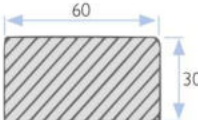
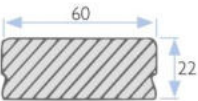
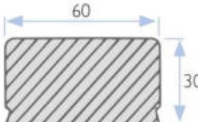
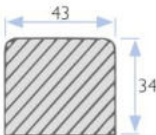
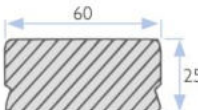
CS0039		CS1212	
CS1213		CS1216	
CS1222		CS1226	
CS1244		CS1250	
CS1252		CS1253	
CS1256		CS1257	
CS1260		CS1262	
CS1263		CS1267	

Sheaths and End Horns

Examples of some of the carrier profiles

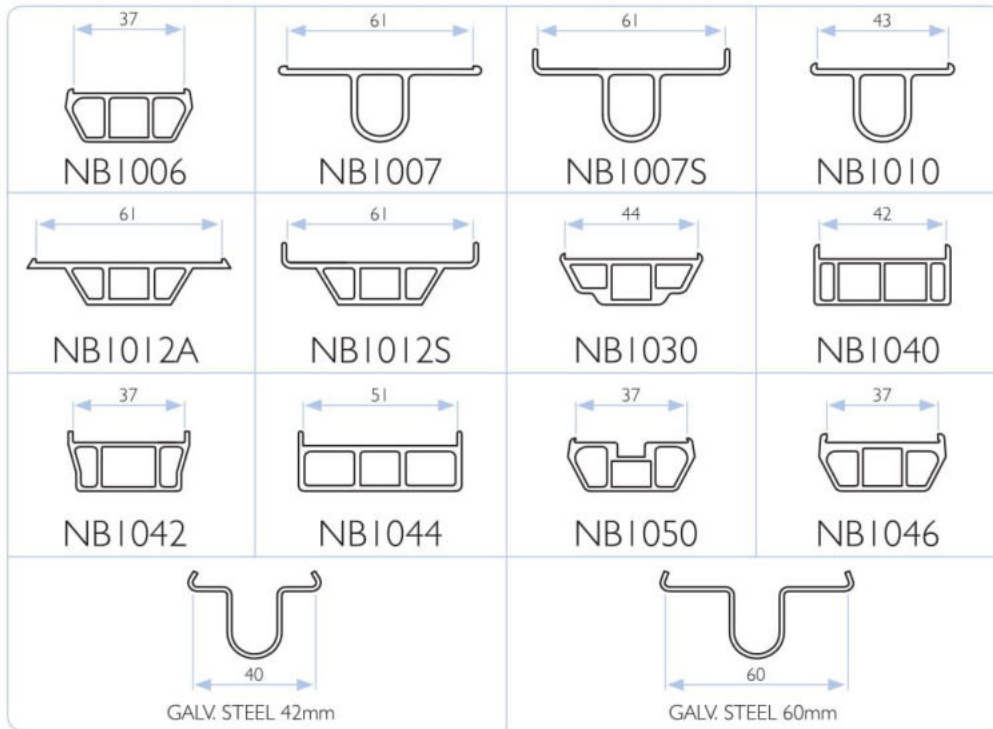

End Horn Casings



The above are standard sheath patterns, however we can design and manufacture to all applications. We also offer an integral end horn designed to meet your requirements.

Research and Development

We are constantly developing new materials and products and have forged many technical partnerships with customers and European Development Projects.

To ensure we maximise on our R&D, we have Machine Testing and Analytical laboratories, these facilities also provide a service for our customers.

Machine Test Laboratory

- Dynamic life testing
- Static Load Testing
- Impact Testing
- Shear strength tests
- High & Low Velocity
- Tensile
- Deflection
- Contraction & Extension Testing

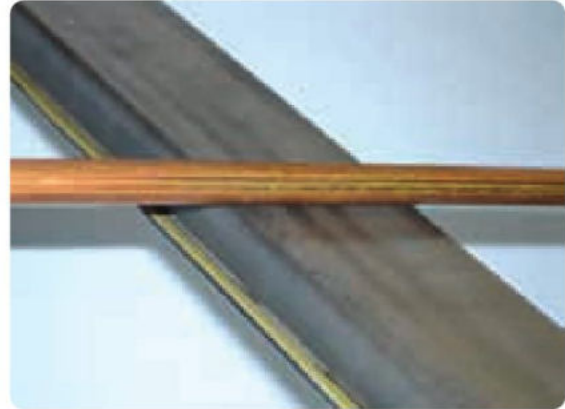

Material Analysis

- Optical microscopy
- Atomic emission spectroscopy
- Atomic absorption spectroscopy
- FTIR spectroscopy
- Thermo gravimetric analysis
- Particle size analysis
- Mercury porosimetry
- Controlled stress rheology
- Thermal expansion
- X-Ray analysis

Sharing the Knowledge

Morgan offer:

- Local Sales Engineering Support
- Application Engineering
- Technical Support Team
- Technology
- Test & Development facilities
- Technical Training Courses either held at customers site, at a Morgan regional business unit or in our technical centre of excellence

Fault-finding reference chart

A	Burnt carbon surface															<p>To use the chart, first select the symptom displayed by your system. Trace the appropriate column down the chart. Stop at each line containing a dot. The wording on the left of the line indicates a probable cause and the wording on the right a possible remedy.</p>
B	Uneven wear along strip															
C	Uneven wear strip tp strip															
D	Grooving															
E	Edge chipping															
F	Cracked carbons															
G	Sparking damage on sheath															
H	Sheath overheating															
J	Short life															
K	Loose carbons															
L	Broken carbons															
M	Missing carbons															
Probable Causes		M	L	K	J	H	G	F	E	D	C	B	A	Possible Remedy		
1	Current overload	●		●	●	●	●			●			●	Reduce current load	1	
2	Low contact force			●	●	●	●		●		●		●	Increase force if possible	2	
3	Poor wire condition		●	●	●		●	●	●	●		●		Check overhead	3	
4	Poor current path			●		●	●				●	●	●	Check current path	4	
5	Wrong material	●	●		●	●		●	●					Check current loading	5	
6	Poor wire stagger	●			●					●		●		Check stagger	6	
7	Pantograph condition	●	●	●	●					●	●	●		Check mechanism	7	
8	Wire suspension	●	●	●	●		●	●	●			●		Type of suspension	8	
9	Sectional insulator setting	●	●	●			●	●	●	●		●		Check setting	9	
10	Pivot angle				●						●			Correct angle	10	
11	Head mass	●	●	●	●		●	●	●	●	●			Reduce mass	11	
12	Mixed materials				●	●				●	●	●		Change to carbon	12	
13	Mixed running				●		●							Fit all one grade	13	
14	Weather conditions	●	●		●		●	●	●				●	Check weather pattern	14	
15	Badly fitted carbons	●	●	●	●	●	●	●		●		●		Check fitting	15	
16	Carbon section too small	●	●		●	●							●	Increase size carbon section	16	
17	Carbon section too big				●									Reduce size carbon section	17	
18	High contact force	●	●					●	●					Reduce force if possible	18	
19	Panto speed	●	●		●		●		●		●		●	Check panto aerodynamics	19	

ABOUT MORGAN ADVANCED MATERIALS



Morgan Advanced Materials is a global engineering company offering world-leading competencies in materials science, specialist manufacturing and applications engineering.

We focus our resources on the delivery of products that help our customers to solve technically challenging Problems, enabling them to address global trends such as energy demand, advances in healthcare and environmental sustainability.

What differentiates us?

- Advanced material science and processing capabilities
- Extensive applications engineering experience
- A strong history of innovation and reinvention
- Consistent and reliable performance
- A truly global footprint
- We find and invest in the best people

Công ty TNHH Trí Lập
Phòng 602+604, tòa nhà Vinahud
Đường Trung Yên 9, Phường Trung Hòa
Quận Cầu Giấy, Hà Nội, Việt Nam

TriLAP Company Limited
Suite 602+604, Vinahud Building
Trung Yen 9 Road, Trung Hoa Ward
Cau Giay Dist., Ha Noi, Viet Nam

T (84-24) 6682 0666
F (84-24) 3226 2435
www.trilap.com.vn
info@trilap.com.vn
Hotline: 0988 738 808